

# Large Frame Hose Reels | Nordic Series 3800

## Heavy Duty Large Frame Reels Petroleum Service

1 1/2" or 2" fluid path for 1 1/4" through 2" I.D. hose

**Rewind:** Chain and sprocket drive powered by A.C. or D.C. electric motor, compressed air motor or hydraulic motor. 30° manual rewind assembly available at extra cost.

**Inlet:** 90° 2" grooved fitting is standard. Straight swivel joints may be specified at no extra cost.

**Gooseneck:** 1 1/4", 1 1/2" or 2" female/male NPT is available. Specify male or female fitting and hose size when ordering.

**Brakes and locks:** Manual friction brake and air operated caliper brake are standard.

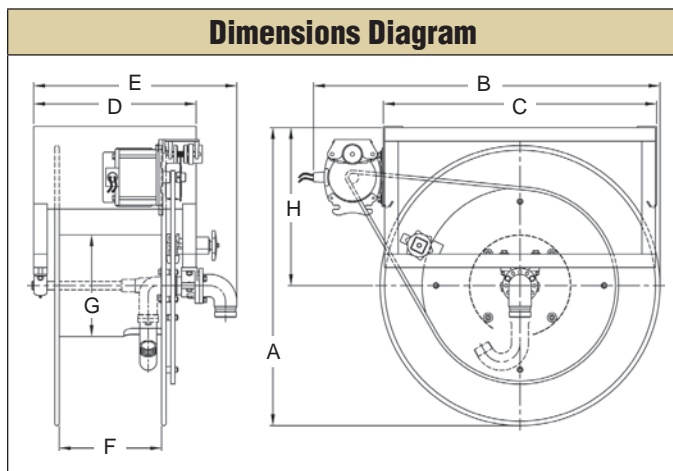
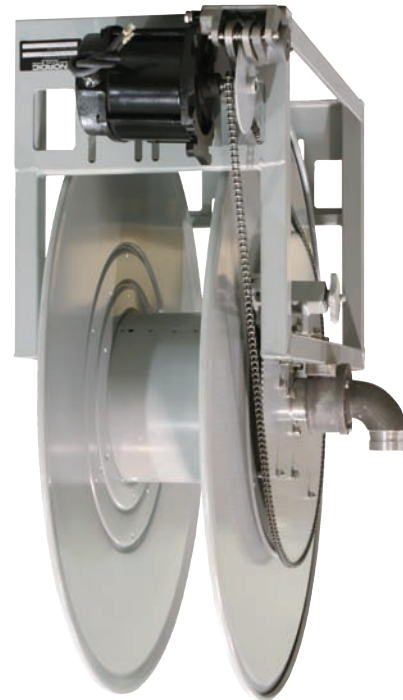

**Made in USA**

Standard seals maximum temperature 174 °F (79 °C) and minimum temperature -20 °F (-29 °C). Extreme temperature seals maximum temperature 400 °F (204 °C) and minimum temperature -50 °F (-45 °C). Standard pressures to 300 psi. Other temperatures or pressures can be furnished at extra cost; consult manufacturer. The standard color for this series is red or gray.

Hose I.D.	in	1 1/4	1 3/8	1 1/2	2	Specification - Hose Capacity and Reel Dimensions											
Hose O.D.	mm	32	35	38	51												
	in	1.813	2.000	2.063	2.563												
	mm	46	51	52	65												
Model	Hose Length					Est. Weight	A	B	C	D	E	F	G	H			
3800-31-10	ft	130	105	85		174 LB	in	33	38.5	30	16	20.25	10	11.25	17.5		
	m	40	32	26		79 KG	mm	838	978	762	406	514	254	286	445		
3800-31-12	ft	155	125	105		176 LB	in	33	38.5	30	18	22.25	12	11.25	17.5		
	m	47	38	32		80 KG	mm	838	978	762	457	565	305	286	445		
3800-31-16	ft	210	170	150		180 LB	in	33	38.5	30	22	26.25	16	11.25	17.5		
	m	64	52	46		82 KG	mm	838	978	762	559	667	406	286	445		
3800-39-7	ft	120	105	105		212 LB	in	41	43.5	32	13	17.25	17	11.25	21.5		
	m	37	32	32		96 KG	mm	1041	1105	813	330	438	432	286	546		
3800-39-9	ft	160	140	140		214 LB	in	41	43.5	32	15	19.25	9	11.25	21.5		
	m	49	43	43		97 KG	mm	1041	1105	813	381	489	229	286	546		
3800-39-11	ft	240	175	175		216 LB	in	41	43.5	32	17	21.25	11	11.25	21.5		
	m	73	53	53		98 KG	mm	1041	1105	813	432	540	279	286	546		
3800-31-13	ft	170	110	110	70	178 LB	in	33	38.5	30	19	24.5	13	15	17.5		
	m	52	34	34	21	81 KG	mm	838	978	762	483	622	330	381	445		
3800-39-12	ft	230	195	165	110	218 LB	in	41	43.5	32	18	23.5	12	15	21.5		
	m	70	59	50	34	99 KG	mm	1041	1105	813	457	597	305	381	546		
3800-39-16	ft	305	255	230	165	224 LB	in	41	43.5	32	22	27.5	16	15	21.5		
	m	93	78	70	50	102 KG	mm	1041	1105	813	559	699	406	381	546		

Refer to page 28 to build a representative model number. Final part number assigned upon quote.

**Built to order, not returnable.**